

**NTB
INTERSTAATLICHE HOCHSCHULE
FÜR TECHNIK BUCHS**



Internationale
Bodensee
Hochschule

Effiziente Wärme- und Kältetechnologien

Prof. Stefan S. Bertsch, PhD
Institut für Energiesysteme IES
NTB Interstaatliche Hochschule für Technik Buchs



EUROPÄISCHE UNION
Europäischer Fonds
für Regionale Entwicklung



Schweizerische Eidgenossenschaft
Confédération suisse
Confederazione Svizzera
Confederaziun svizra



Inhalt



Internationale
Bodensee
Hochschule

- + Vorstellung IES
- + Übersicht Technologien
- + Projektbeispiele
- + Diskussion



EUROPÄISCHE UNION
Europäischer Fonds
für Regionale Entwicklung



Schweizerische Eidgenossenschaft
Confédération suisse
Confederazione Svizzera
Confederaziun svizra



interreg IV
Alpenrhein | Bodensee | Hochrhein



Ausrichtung des IES

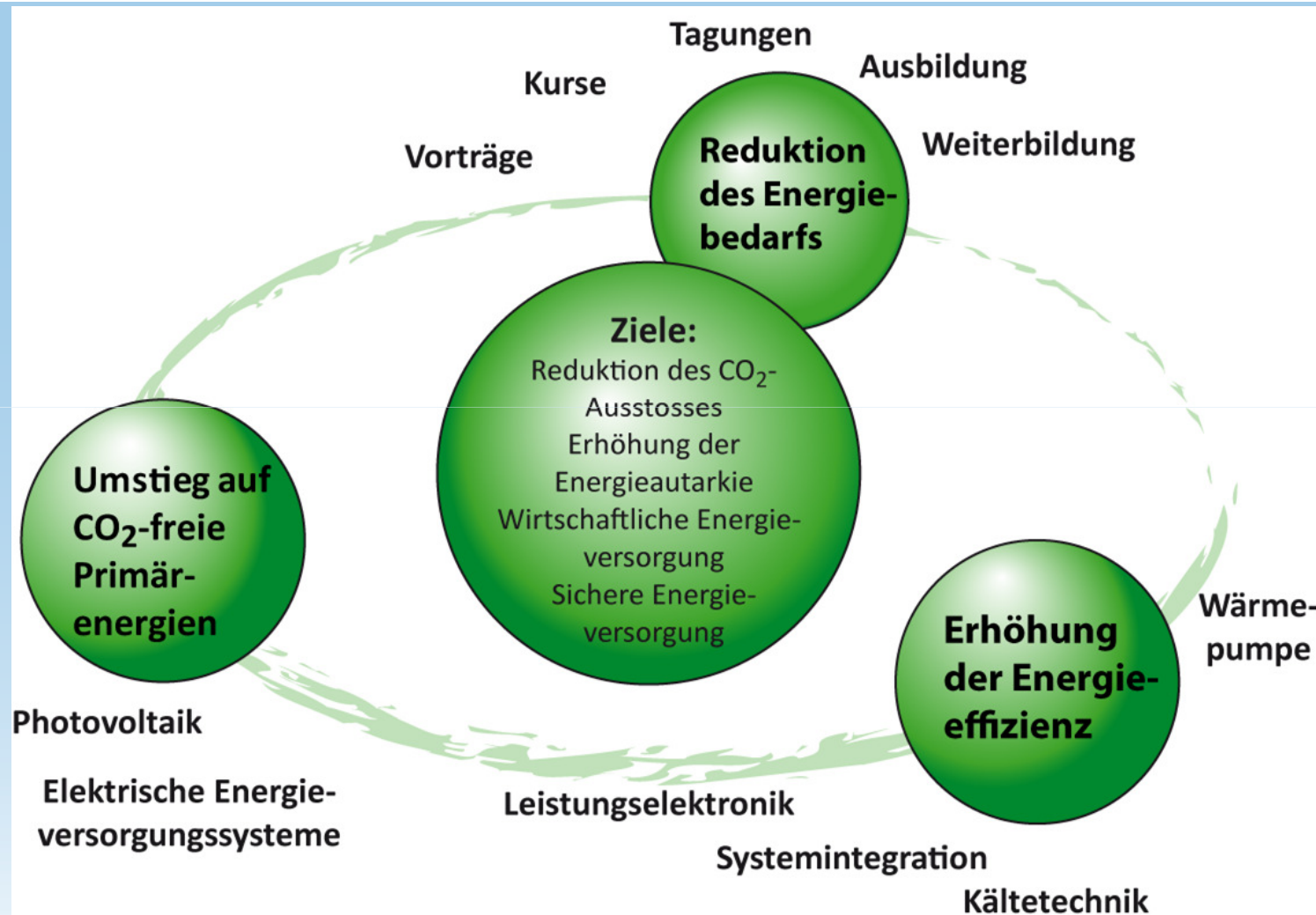



Angebote NTB

- + Forschungsprojekte
- + Beratung und Dienstleistung
- + Marktstudien
- + Patentrecherchen
- + Analysen und Machbarkeitsstudien
- + Produkt- und Verfahrensentwicklung
- + Prozessoptimierung
- + Schulung und Weiterbildung





Forschung und Dienstleistung

- + Bachelorarbeiten
- + Masterarbeiten
- + Direktaufträge
- + Dienstleistungen (WPZ)
- + KTI/BFE/IBH Projekte





Energiesparpotential

- + 20% des Stroms und 60% der Wärme könnten bei konsequenter Anwendung heutiger Technologien eingespart werden (Sattler Consulting, Österreich)
- + In der gezielten Optimierung des Ressourceneinsatzes kann ein beträchtliches Sparpotenzial von 30 – 50% realisiert werden (BFE, 2008).

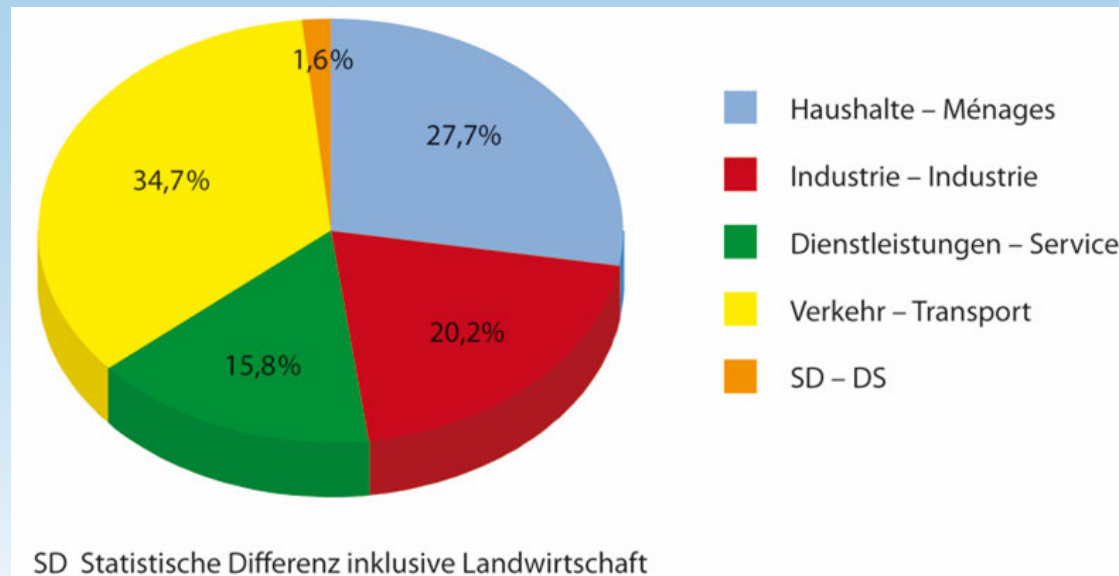



Wärmepumpen (CH)

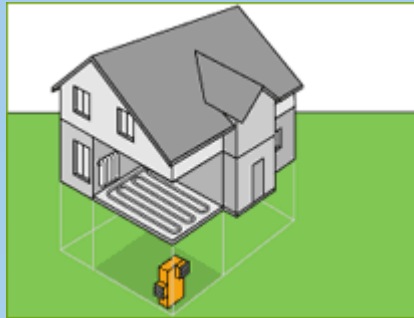

Luft-Wasser

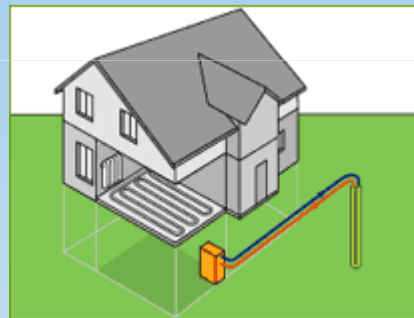

Sole-Wasser

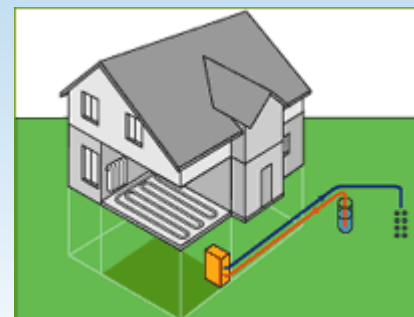

Wasser-Wasser

2008 wurden verkauft

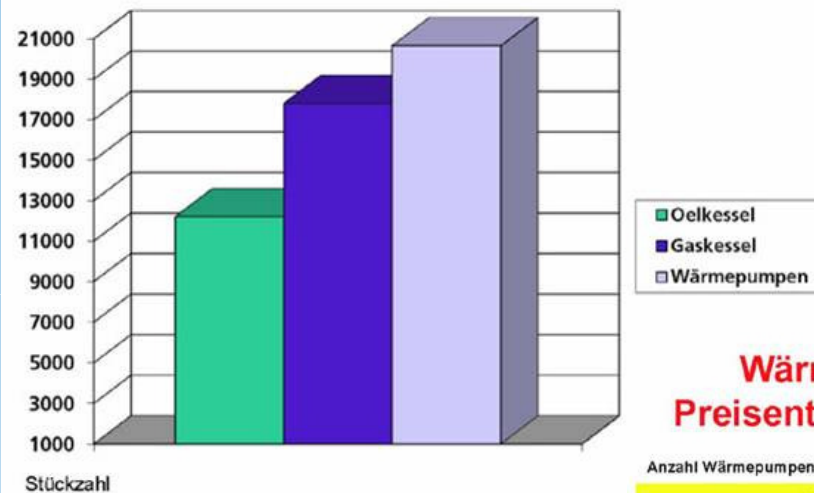

2008 starker Anstieg
auch im
Sanierungsmarkt

Wärmepumpen-Verkäufe und
Preisentwicklung von SW/WP 7,6 kW

Anzahl Wärmepumpen 2008: 20'670

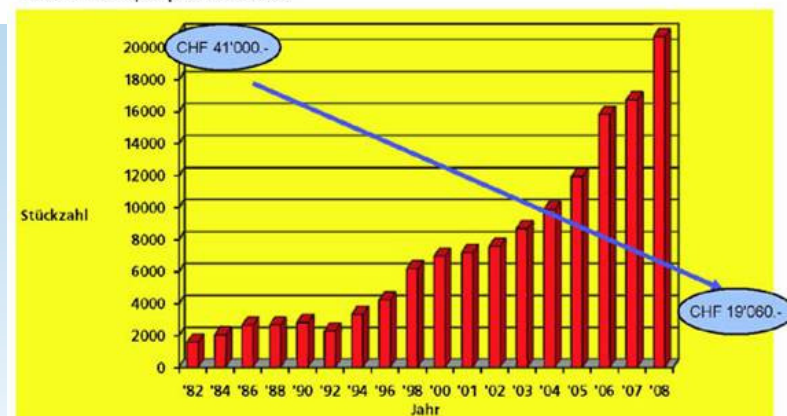

Quelle: www.fws.ch





Wärmepumpe – Gutes Beispiel

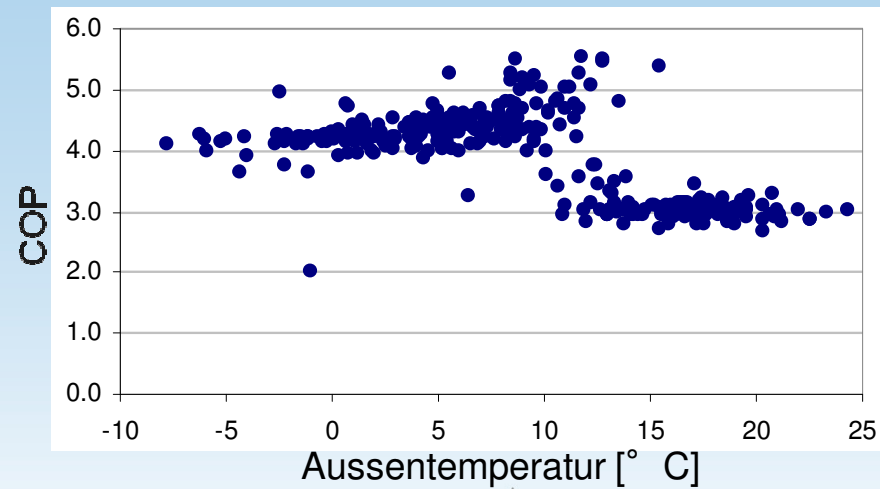
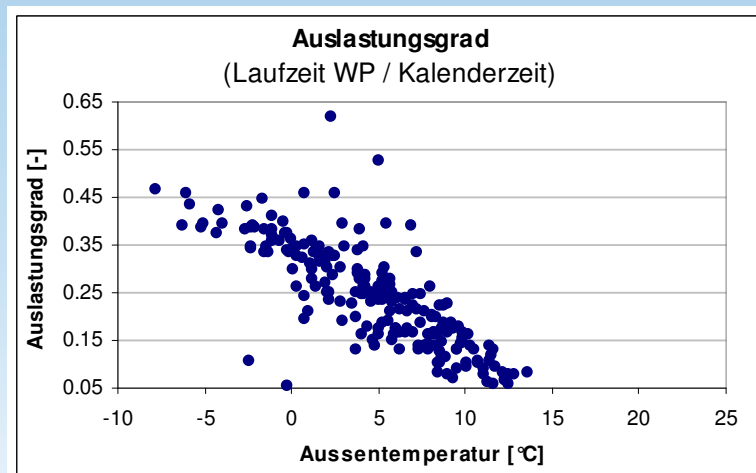
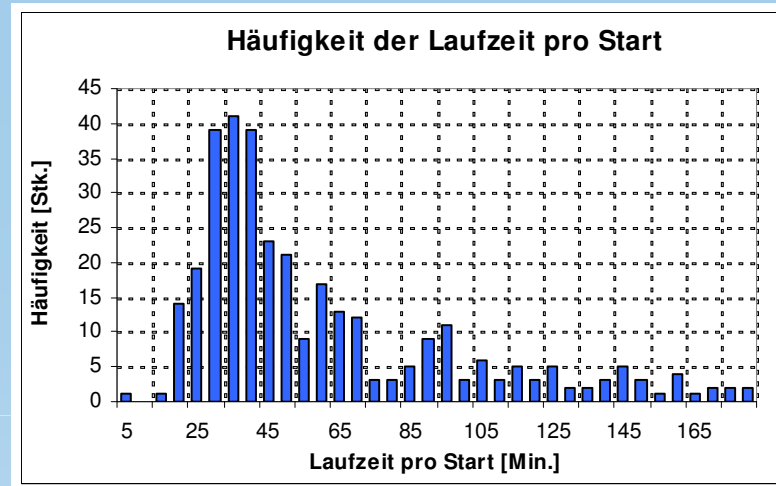
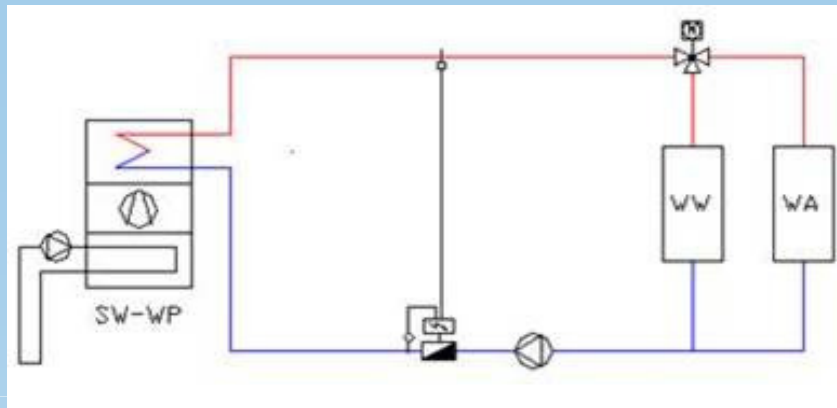

JAZ = 4.3

Quelle: BFE, FAWA





Wärmepumpe – Schlechtes Beispiel

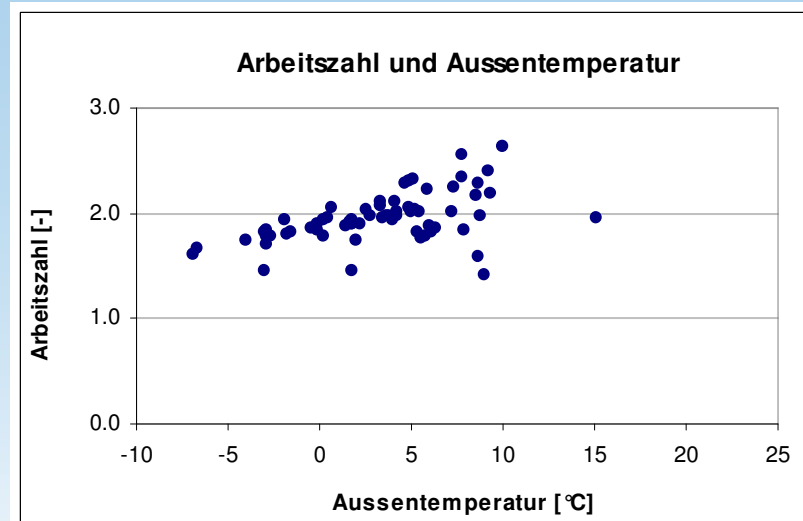
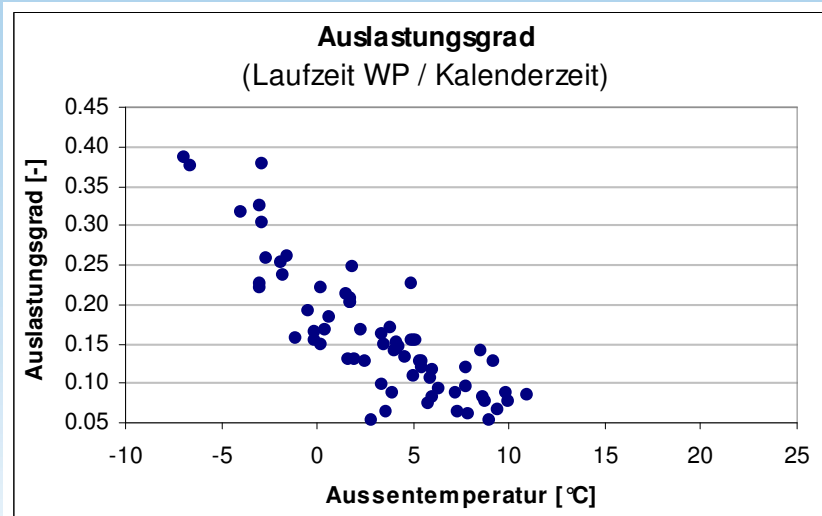
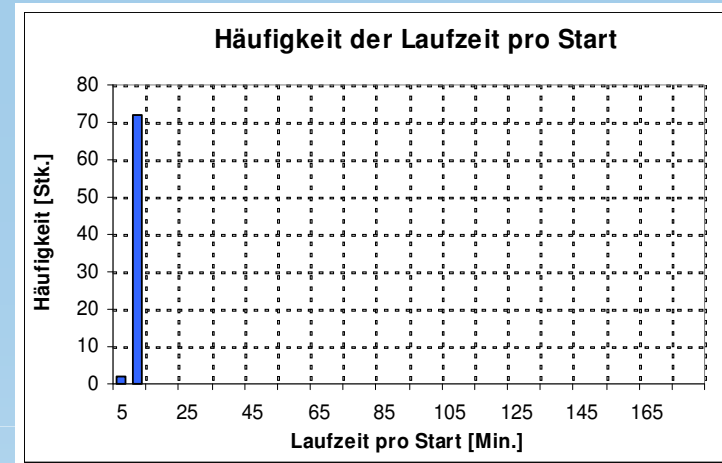
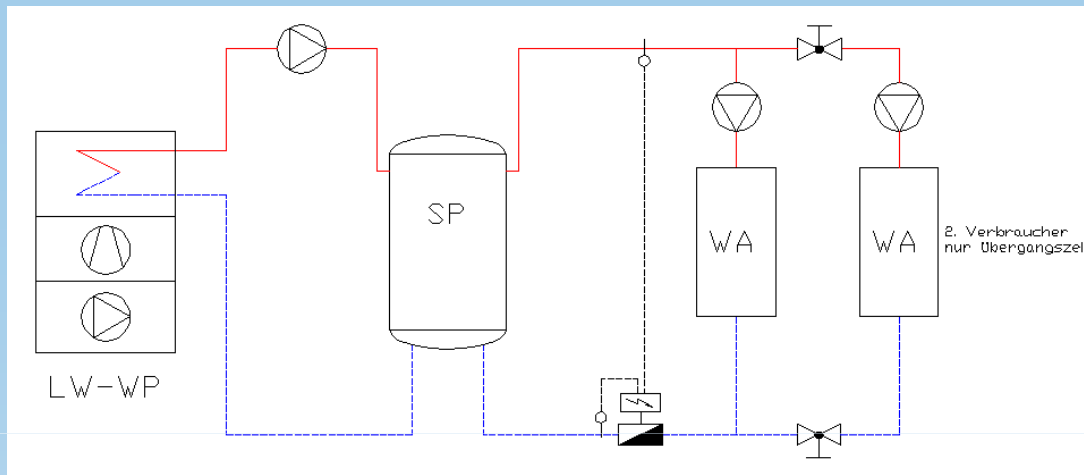

JAZ = 1.9

Quelle: BFE, FAWA



EUROPÄISCHE UNION
Europäischer Fonds
für Regionale Entwicklung



Schweizerische Eidgenossenschaft
Confédération suisse
Confederazione Svizzera
Confederaziun svizra





Wärmepumpe

- + Einfache Systeme sind effizienter
- + Gesamtsanierung des Gebäudes beim Ersatz einer Feuerung
- + Freecooling mittels Erdwärmesonden
- + Abwärmenutzung
- + Interessantes zum Thema Wärmepumpe:
www.fws.ch

CO₂ Ausstoss

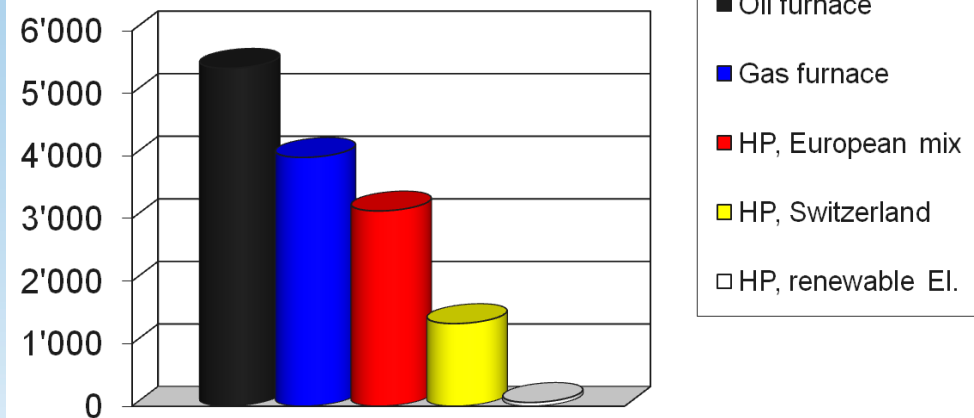



Wärme und Kälte - Ressourcennutzung

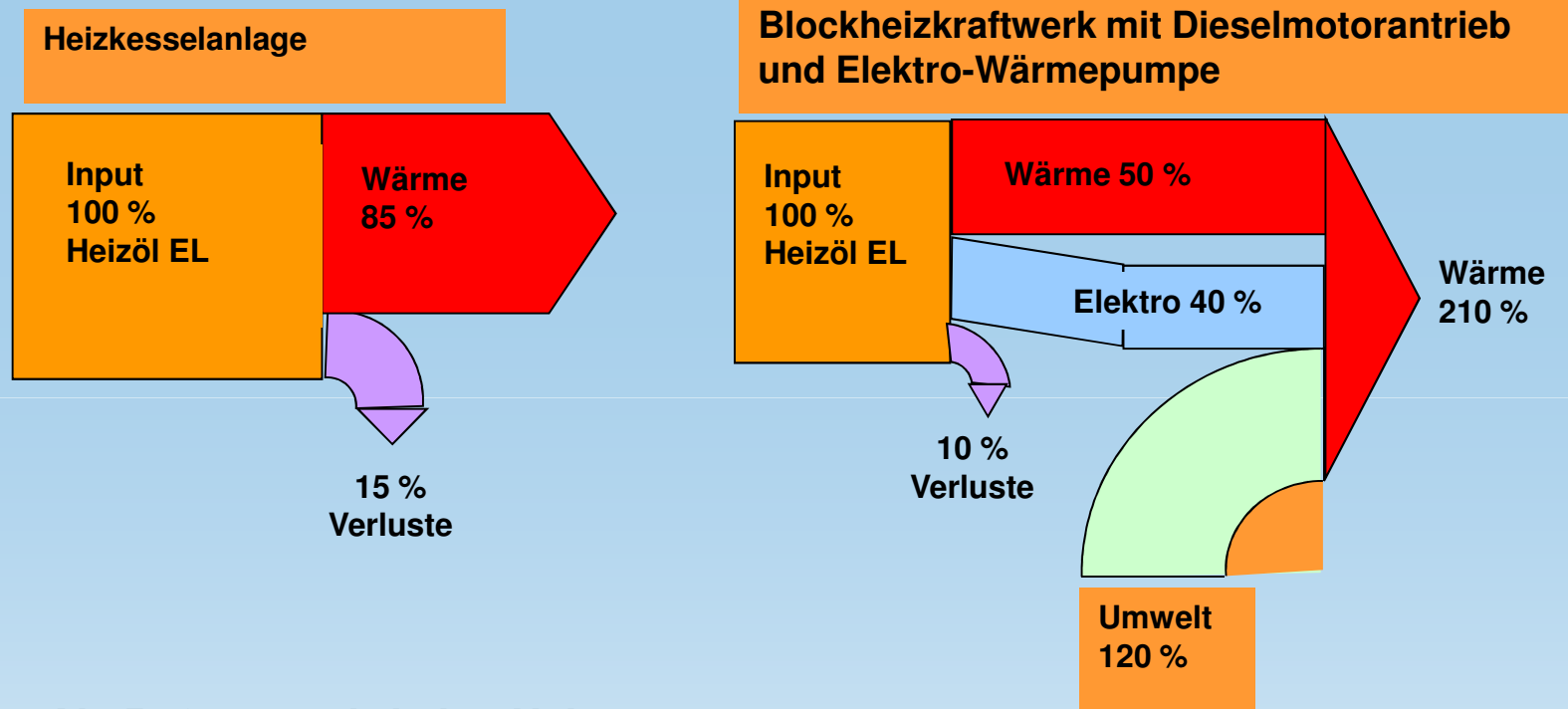

Als Referenz wird eine Heizkesselanlage mit Heizöl verwendet.

Mit dem Einsatz des BHKW wird bei gleicher Menge Heizöl die nutzbare Energiemenge fast um Faktor 2.5 gesteigert.





Alternative Wärme und Kälte

- + Absorptionsmaschinen
- + Sorptionsmaschinen
- + Brennstoffzellen
- + Blockheizkraftwerke
- + Wärmeverbund
- + Solares Kühlen
- + Abwärmenutzung
- + Luft-Luft Systeme

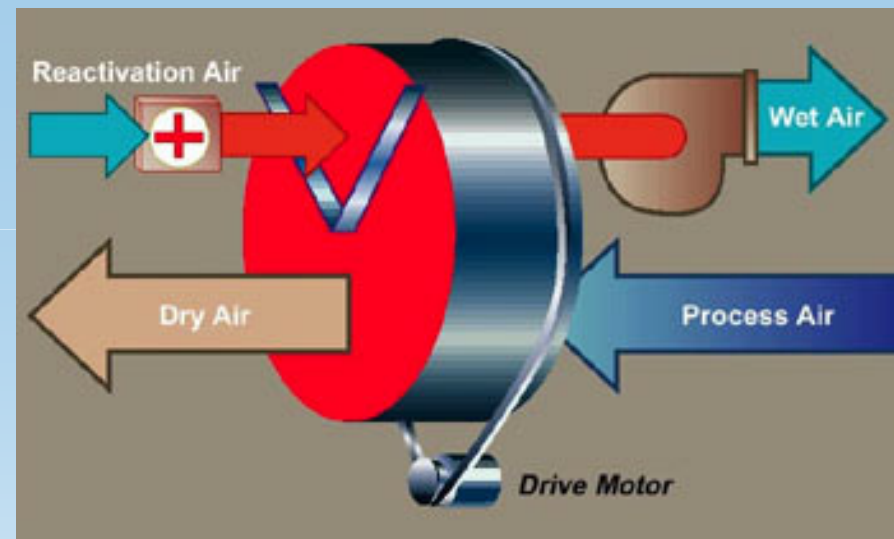

Energiezukunft



Internationale
Bodensee
Hochschule

- + Herausforderungen
 - + Energieerzeugung
 - + Energiespeicherung
 - + Verbindung von Ökologie und Ökonomie
- + Kombination verschiedenster Energiequellen
- + Intelligente Systeme
- + Kombination Strom und Wärme



EUROPÄISCHE UNION
Europäischer Fonds
für Regionale Entwicklung



Schweizerische Eidgenossenschaft
Confédération suisse
Confederazione Svizzera
Confederaziun svizra





Neue Technologien - Wärmepumpe

- Hochtemperaturwärmepumpen
- Alternative Kältemittel
- Alternative Kältekreisläufe

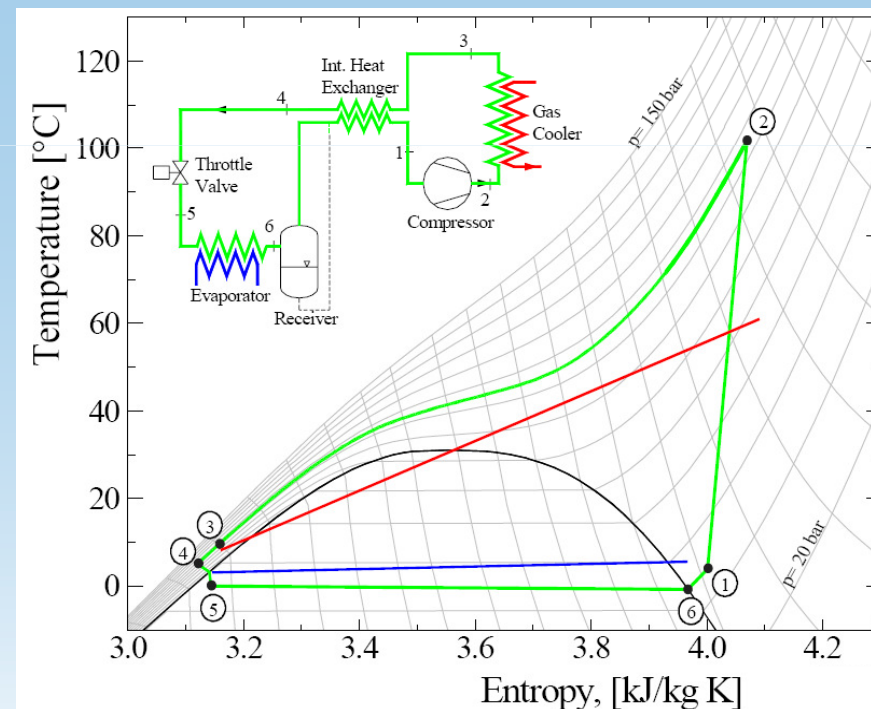
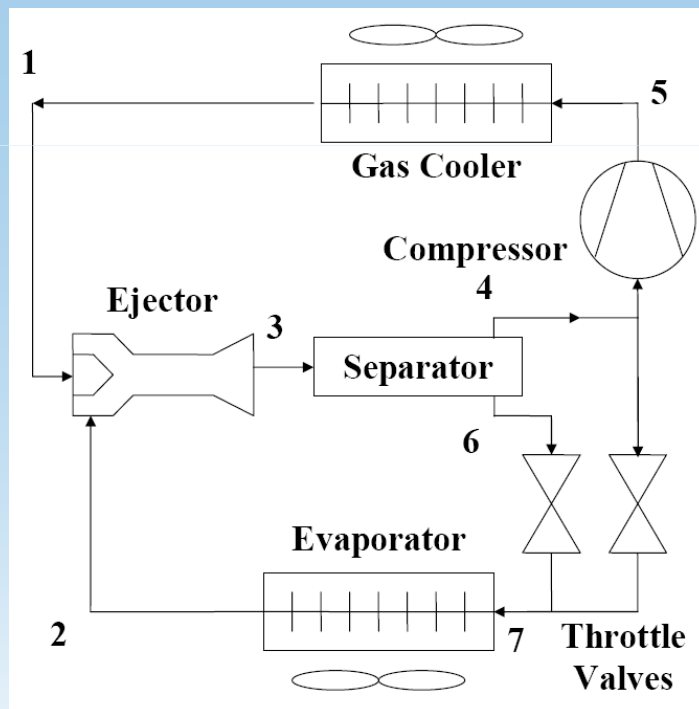



Projektbeispiel: Elektroauto

- 2 Hybrid-Synchron Motoren
95kW je Hinterrad
- Drehmoment an den Rädern:
total 2200 Nm ab 0 km/h
- Beschleunigung:
max. 6s bis 100 km/h
- Keine Schaltpausen
- Höchstgeschwindigkeit:
> 200 km/h





Projektbeispiel: Elektroauto

- **Solarzellen:** 30 Quadratmeter reichen für ca. 20'000 km pro Jahr.
- **Wärme-Kraft-Koppelung:** Kleinstkraftwerke zur Erzeugung von Wärme und Strom; z.B. Öl- oder Pelletsheizungen mit Stromproduktion.
- **Kein Feuer ohne Strom!**
- **Rationelle Verwendung:** Energiemanagement, Wärmepumpen, etc.
- **Alternative Erzeugung:** Windkraft, Erdwärme, Solarstrahlung, Wasserkraft

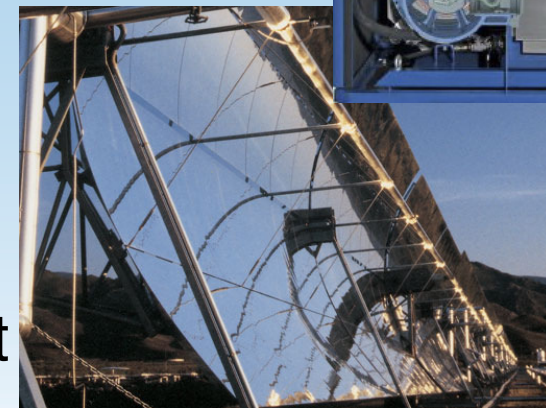



Forschungsprojekt - Fluidglas

Projektziele:

Prototyp eines Fassadensystems mit dem die Energietransmission kontrolliert werden kann.
Verbesserung von Komfort, Energieverbrauch und Raumnutzung.

Projektstatus:

Untersuchung verschiedener Energietransmissionskonzepte und Aufbau eines Prototyps.





Forschungsprojekt - Fluidglas

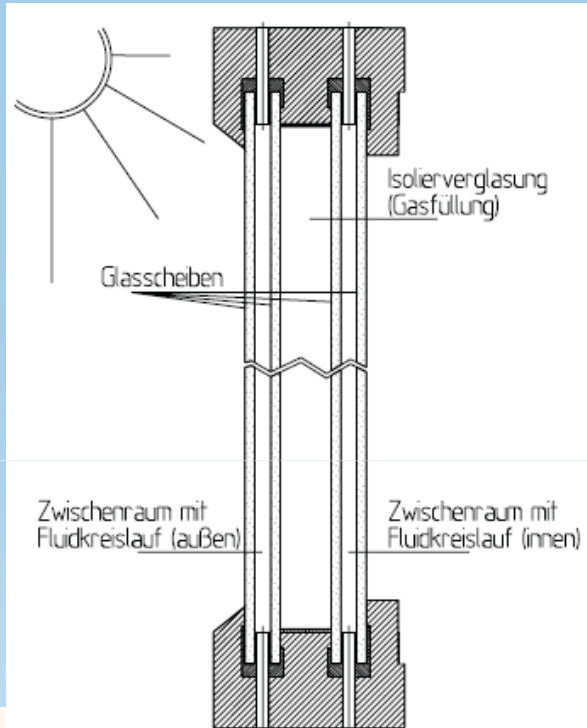

Projektpartner:

- + Hochschule Liechtenstein
- + Interstaatliche Hochschule für Technik Buchs
- + GLASSX AG
- + HOVAL Management AG
- + ECKELT GLAS GmbH
- + Hilti AG

Sponsoren:

- + Internationale Bodensee Hochschule
- + Hochschule Liechtenstein

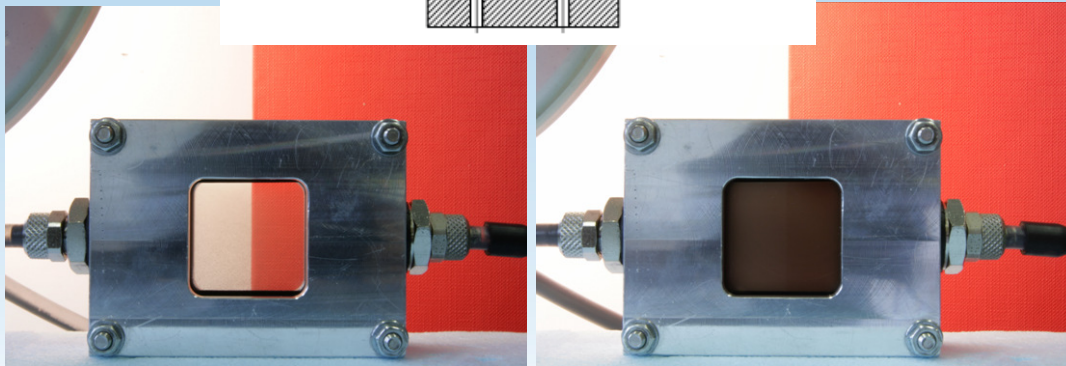

Projektbeispiel: Energieautarkes Wohnhaus



Internationale
Bodensee
Hochschule

- + Erstellung eines Konzeptes für ein energieautarkes Wohnhaus. Energetische und ökonomische Beurteilung von Heizung, Lüftung und Klima.
- + Vergleich von Photovoltaik- und Solarthermie.
- + Erstellung einer Auslegesoftware.

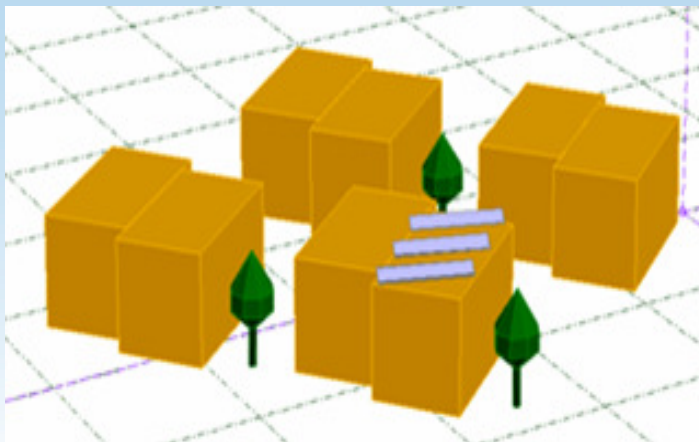

Einfluss Energiepreisentwicklung

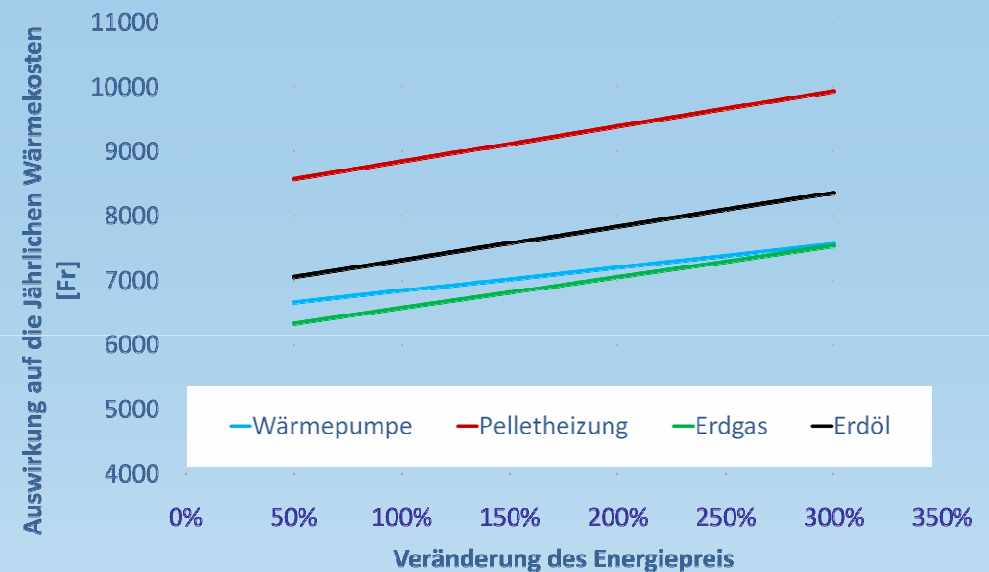

Sponsoren:

Förderverein Institut Energiesysteme mit
Unterstützung des Landes Liechtenstein



EUROPÄISCHE UNION
Europäischer Fonds
für Regionale Entwicklung



Schweizerische Eidgenossenschaft
Confédération suisse
Confederazione Svizzera
Confederaziun svizra





Projektbeispiel: Dynamische Wärmepumpe

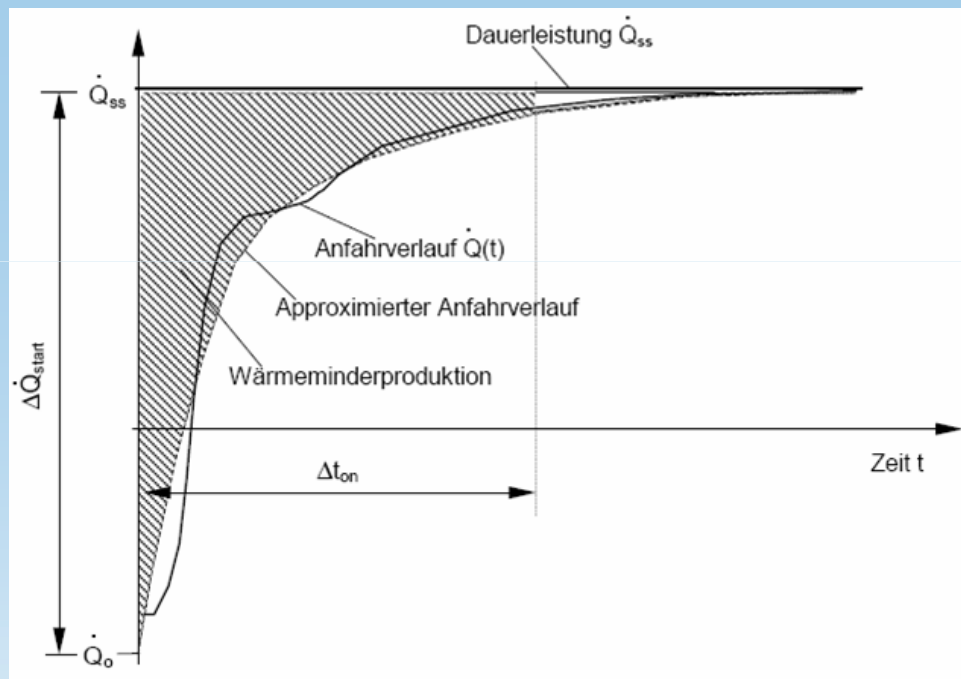

Ziel:

Entwicklung eines Berechnungsmodells um Einschaltverluste von Wärmepumpen zu charakterisieren.

Projektpartner:

Bundesamt für Energie



Kontakt



Internationale
Bodensee
Hochschule

NTB Interstaatliche Hochschule für Technik Buchs
Institut für Energiesysteme
Werdenbergstrasse 4
9471 Buchs

Tel. +41 (0) 81 755 34 69

Fax +41 (0) 81 755 34 34

ies@ntb.ch

www.ntb.ch/ies



EUROPÄISCHE UNION
Europäischer Fonds
für Regionale Entwicklung



Schweizerische Eidgenossenschaft
Confédération suisse
Confederazione Svizzera
Confederaziun svizra

